

# **Forging Material Handling System** **(For Swagelok Company)**

Mechanical Engineering Department  
Fenn College of Engineering  
Cleveland State University

MCE 450 Design Project  
Fall 2005

Submitted By:  
Roy Aukerman  
Justin Bellini  
Michael Glover  
Kevin Gollon

## **I. Executive Summary**

This design project examined and solved a manufacturing process problem which was costing the Swagelok Corporation time, money, and most importantly, the safety of its workers. The current manufacturing process being used, which is inadequate, uncontrollable and constantly putting the operator at risk for injury, requires the operator to “catch” a hot billet at 2300 F from an elevated feed conveyor to a hydraulic press staging area below.

This design project has focused on a simple solution which is operator friendly with few mechanical parts. The main principle to the design is to control the hot billet from the feed conveyor to the operator pickup area while minimizing the amount of potential energy resulting from high elevated drop off location. This is achieved through an escapement chute which diverts the hot billet into a controlled holding position. Once at this location, the hot billet is then released onto a slide chute which allows it to roll down into a bin in a controlled manner.

Ultimately, the installation of this simple design will not only be safer, but will save approximately \$56,000 as projected over one year’s time. When analyzing the effective cost of down-time which results from the existing system, the repayment period of this new system is approximately 2 ½ weeks, due to the minimal investment of \$3,000. As a result, it will be shown that this design is a reasonable answer and solution to an existing unsafe situation and nagging problem.

## **II. Abstract**

The focus of this design project was to modify an existing design of a material handling system that transports hot metal billets (2300°F) from a feed conveyor to an operator station for processing. The existing design utilized a gravity fed system whereby a hot metal billet is dropped onto a chute where it slid and bounced down approximately two feet to an operator station located below the feed conveyor. The handling of the falling billet must be anticipated, which not only produces random results, but results in a safety issue as well, due to the oily environmental conditions. The new system design utilizes the existing controller devices present such that the transport of multiple-sized billets is controlled and is repeatable. The hot metal billet will then arrive in the same location, on time, every time, thus providing a safer and more productive work environment. The newly designed escapement chute must be robust and capable of withstanding the extreme temperatures of these hot billets. Heat transfer to mating equipment must be controlled and or prevented as a part of the “long term solution”. In addition, the final system designed, is not only safe and reliable, but is also easy to maintain, utilizing only one technician for debugging, repairs and maintenance.

### III. Table of Contents

I.	Executive Summary .....	2
II.	Abstract .....	3
III.	Table of Contents .....	4
IV.	Table of Figures .....	5
V.	Introduction .....	6
A.	Background of Impaction Company .....	6
B.	Existing material handling system .....	7
C.	Existing problems and inadequacies with current system .....	9
VI.	Project Objectives .....	13
VII.	Impact of Design .....	14
VIII.	Detailed Project Description .....	15
A.	Timeline .....	17
B.	Breakdown of Sub-Projects .....	22
C.	Cost / Return on Investment .....	26
IX.	Analysis and Modeling .....	28
X.	Summary .....	35
XI.	Appendix A .....	36

## IV. Table of Figures

Figure 1 - Typical billet shape .....	7
Figure 2 - Existing conveyor and heater showing billet exiting heater .....	9
Figure 3 - Forging press cross-section .....	10
Figure 4 - Actual forging press area .....	11
Figure 5 - Escapement Chute concept .....	16
Figure 6 - Overall system layout – Concept #2 .....	17
Figure 7 - Project Gantt chart.....	18
Figure 8 - Electric schematic .....	24
Figure 9 - Pneumatic schematic.....	25
Figure 10 - Estimated costs.....	26
Figure 11 - Schematic drawing for analysis .....	29
Figure 12 - Graphical Linkage Analysis.....	31
Figure 13 - Thermal insulation .....	33

## **V. Introduction**

### **A. Background of Impaction Company**

Impaction Company, based in Solon Ohio, is a division of the Swagelok group of companies. Impaction Company was started in 1967 with the purpose of providing high quality forgings to other groups in the Swagelok Company and continues to supply forgings for the chemical, petrochemical, biopharmaceutical, semiconductor and other fields as well. The initial technology used to create these forgings was a 'High Energy Rate Forging' process that accommodated stainless steel part sizes up to approximately 1.5 in<sup>2</sup> in cross-sectional area and 2.5 in<sup>3</sup> in volume. In response to customer demand for larger forgings, the company later invested in press forging technology with several presses sized up to 1600 metric tons. This investment allowed for stainless steel forgings up to 4.0 in<sup>2</sup> in cross-sectional area and 24 in<sup>3</sup> in volume.

There are several advantages of making forgings in-house that set Impaction Company apart from outside suppliers. The ability to provide quick turn around for customer orders has compressed the timeline for availability of new forgings from more than 12 weeks to an average of two weeks for rush orders. The ability to provide short run quantities, often less than 10 pieces, gives Impaction Company a significant advantage over outside suppliers that frequently require minimum lot sizes of several hundred parts. These advantages have made Impaction Company the default forging supplier for Swagelok Company for any parts that are sized within the press capacity of the facility.

In general the current press forging process is accomplished in the following manner. Stainless steel billets progress from a vibratory feeder where they are fed through an induction heater that heats the billets to a required forging temperature of 2300 °F. The heated billets then move from the heater to the press area via a gravitational feed chute and are progressively moved through forging stations by an operator. The operator is required to manual handle the hot billet with long tongs through each press station operation. The final station is a hot trim operation that punches the forged part from the work piece. The forged part then moves by conveyor to a water quench tank and is then removed from the tank to staging bin, via conveyor, where the process is complete.

## **B. Existing material handling system**

Stainless steel bars are cut to length into billets prior to entering the vibratory feeder (described previously), an illustration of which is shown in (Figure 1). The

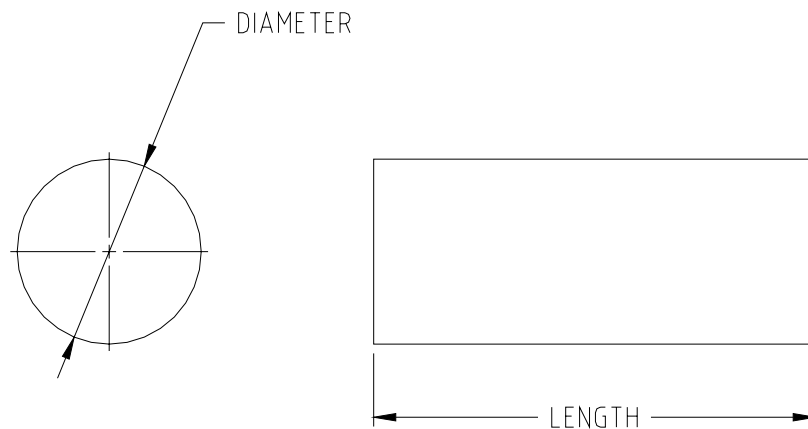
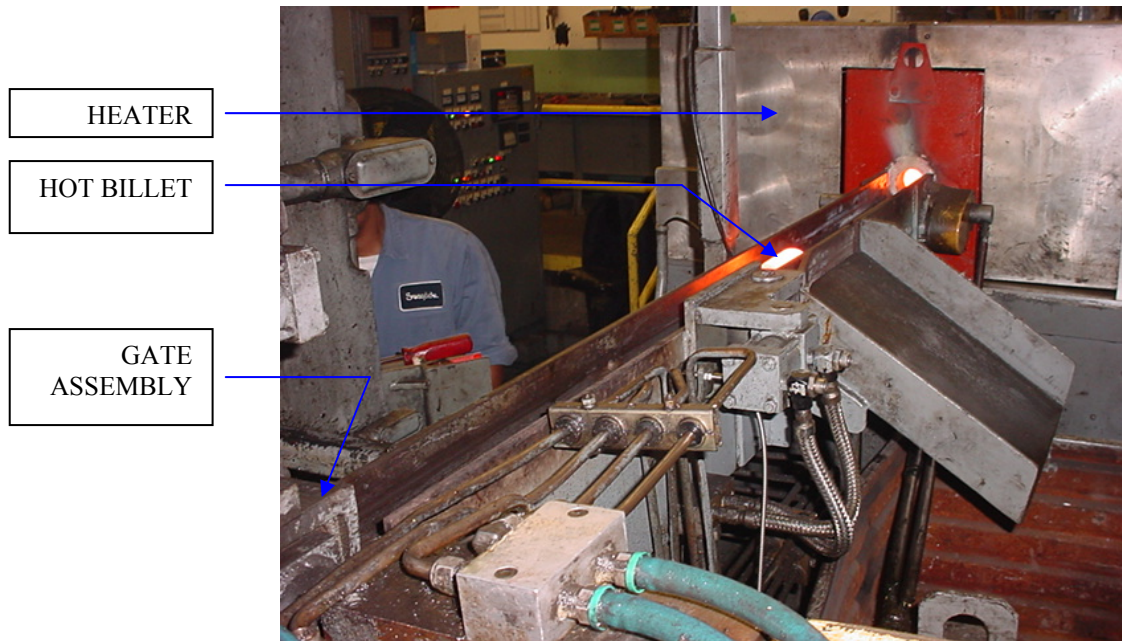

**Figure 1 - Typical billet shape**

billets to be processed vary in diameter and length, but only one type of billet is processed at a time. The range of billet sizes is from a minimum size of 5/8" in diameter by 3" in length to 2 1/2" in diameter by 6" in length.

The billets to be processed are originally placed in a vibratory bowl feeder, from which they exit into and through an induction heater. The induction heater continuously heats the billets to approximately 2300 °F. Upon exiting the heater, an infrared camera determines the temperature of the individual billets. If the heated billet is outside of the acceptable temperature range, a conveyor system diverts it to a bin for re-heating at a later time. Billets deemed acceptable are transported by the conveyor system past a proximity switch that senses its passage. The proximity switch activates a gate mechanism that traps the hot billet on the conveyor while the conveyor remains in motion. Another proximity switch senses the billet's presence in the gate area, activating a pneumatic cylinder that pushes the entire gate assembly forward, including the billet, from the conveyor.





**Figure 2 - Existing conveyor and heater showing billet exiting heater**

The billet drops from the gate area and the gate then retracts to its original position. After leaving the gate, the billet is gravity fed down a chute, directed normal to the conveyor-gate system, to the operator area. The operator takes care to catch the billet with tongs near the end of its fall down the chute, less it bounce and exit the chute area. The operator then manipulates the billet with tongs and progressively moves it through three forming stations, located immediately beneath the forging press area. A hot trim operation completes the forging process and the resulting part falls into a water quench tank. After quenching, the parts are conveyed from the quench tank to a hopper for transport to subsequent operations.

### **C. Existing problems and inadequacies with current system**

There were several opportunities for improvement to be made to the current gravity fed system each of which will now be discussed. First, the existing material

handling design used a gravity fed chute to deliver the billet from the conveyor system to the operator area for further processing. As a result of the current system layout, there is a 26-inch vertical drop from the conveyor system to the operator area. A free fall of about 4 inches occurred before the billet hit a diverter chute (see Figure 3).

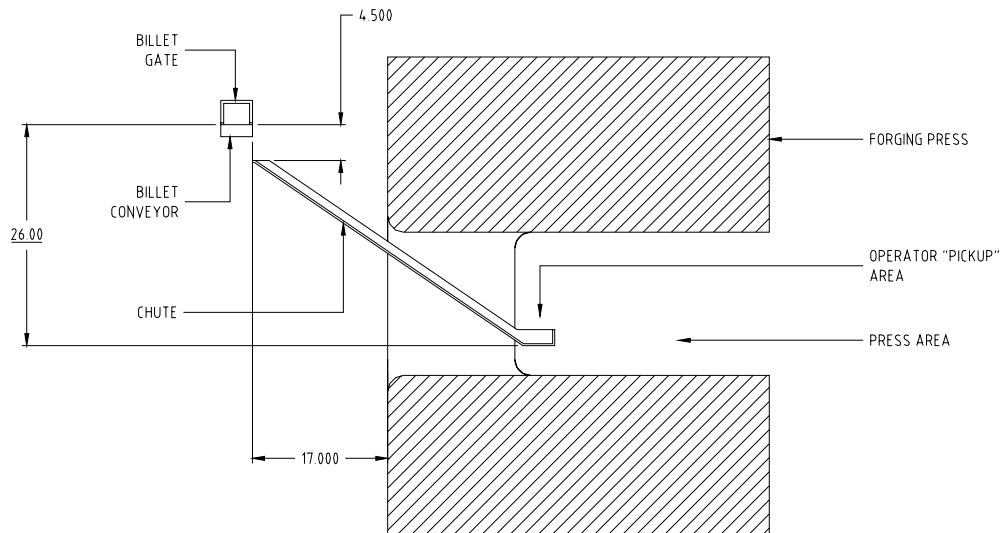
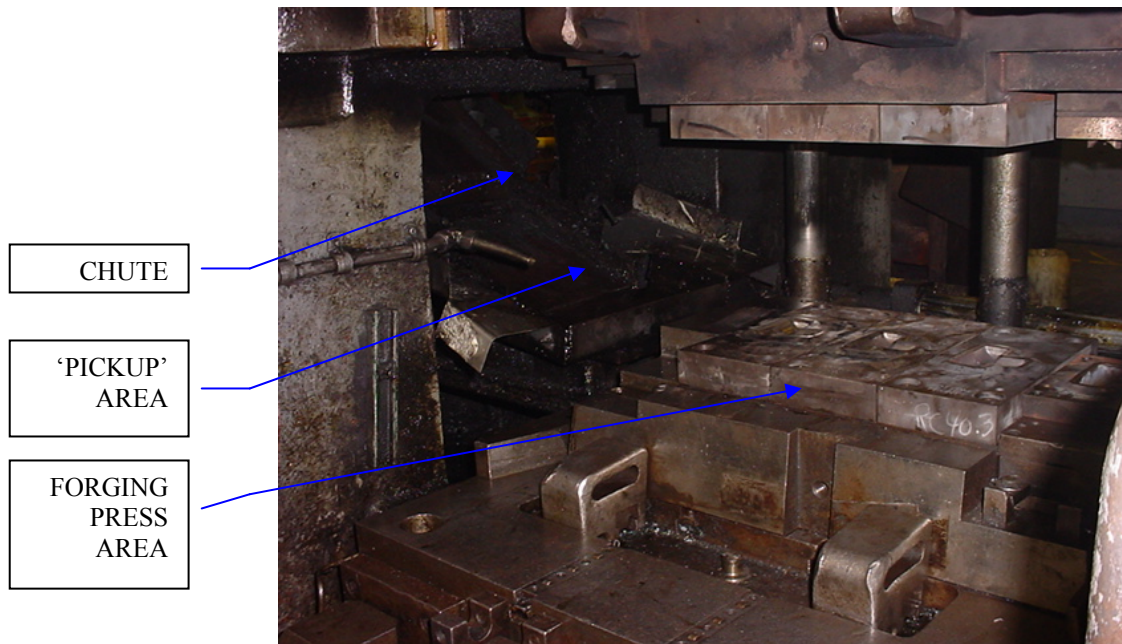

**Figure 3 - Forging press cross-section**

When the part hit the diverter chute, the intent was for it to slide down and be contained within a small bin at the bottom of the chute. However, in practice, the free fall and subsequent chute impact process often caused the part to begin to tumble and spin uncontrollably as it travels down the chute, resulting in erratic and random part location in the operator “pickup” area.

Second, the gravity fed chute did not consistently deliver the parts to a predictable location in the operator “pickup” area nor did it consistently orient parts in any particular manner. This forced the operator to anticipate the fall of the part, and then try to guide the tumbling billet with tongs in order to consistently move it to the end of the chute into the

“pickup” area. If the operator missed the billet, it may tumble from the “pickup” area across the forging press area to the floor or even to the underside of the press.



**Figure 4 - Actual forging press area**

Finally, due to the oily, greasy environment of the forging process, the hot metal billets tumbling from the operator “pickup” area would typically introduce safety concerns and problems. To elaborate, if a part tumbles out of the containment area, it could fall beneath the chute into the base of the press. This area typically contains large amounts of grease, which is a by-product of the automatic greasing system incorporated into the press. The hot billet could then cause a grease fire that the operator must extinguish. As a result, the operator would be required to shut down the press and billet heating process, which, in turn, reduces productivity. Parts that cannot be retrieved beneath the press are lost and lead to higher scrap rates, but more importantly, once the induction heater is shut down, all the billets within the heating oven at that time must be

purged and the entire forging process restarted. This clearly wastes time, energy and resources, in addition to causing undue operator stress, and fatigue, and even injury.

## **VI. Project Objectives**

The purpose of this project was to re-design, and build a material handling system that would transport hot stainless steel billets from an induction heater to a forging press. The process must move billets of various sizes from the induction heater conveyor to the operator 'pickup' area in a reliable and repeatable manner. The design of the system must be extremely reliable with low maintenance and repair costs. Functionality of the system is of paramount importance and visual aesthetics need not be considered for this design. As always, cost is critical to the project, but a more significant upfront investment would be considered if the design stresses robustness and reliability. The design must meet certain size and weight constraints. The overall size of the system will be limited to the opening into the press, which is an area 24 inches wide by 18 inches high. In addition, the weight constraint requires that no one part can be more than 65 lbs. such that one person is capable of assembling, repairing and maintaining the new system. In short, it must be light and compact enough for the maintenance person to install and remove it from the press area.

## **VII. Impact of Design**

A successful redesign will address the billet control issue. Billets will be transported from the conveyor to the 'pickup' area in a repeatable, safe manner, while in turn, solving the problem of billets tumbling from the operator 'pickup' area to the underside of the press and starting grease fires. By solving the issue of billets being lost beneath the press, the scrap issue associated with said billets will be addressed as well. The establishment of repeatable placement will ultimately improve productivity and increase safety while decreasing operator fatigue and overall stress.

Impaction Company has made available funds to purchase necessary components required of the new design, and will provide basic tool room machinery to assist in the fabrication of components not available for purchase. Management, engineering, and maintenance associates will also be available to provide technical assistance and advice to the design team.

## VIII. Detailed Project Description

The existing forging press layout and conveyor constrained the overall size and layout of the design. Due to the extremely tight and inflexible constraints as shown in Figure 3, early initial design concepts, considered by the team, which utilized a “straight” line approach, whereby the billet would travel directly from billet conveyor to operator pickup area, were disregarded. As a result, the initial design concept chosen for this project focused on compact billet transfer that is controlled and reliable. It was also concluded that at each stage of the material movement, the location of the billet must be known. Therefore, proximity switches, have been incorporated at the defined billet transfer location and is then integrated within the existing programmable logic controller that regulates the operation of the press.

The initial concept required the hot billet to travel on the existing conveyor from the induction heater into an escapement gate where it was captured. At this location the billet is fed into fabricated steel chute, which diverted the billet to fall downward. The steel escapement chute consists of sheet metal that will contain the billet on all sides with a hinged door located at the bottom, which is mounted at an angle trapping the cylindrical billet into a “release” location (see Figure 5). A control cylinder (not shown), connected to the hinged door, will release the billet from the chute and into a basket in a controlled manner.

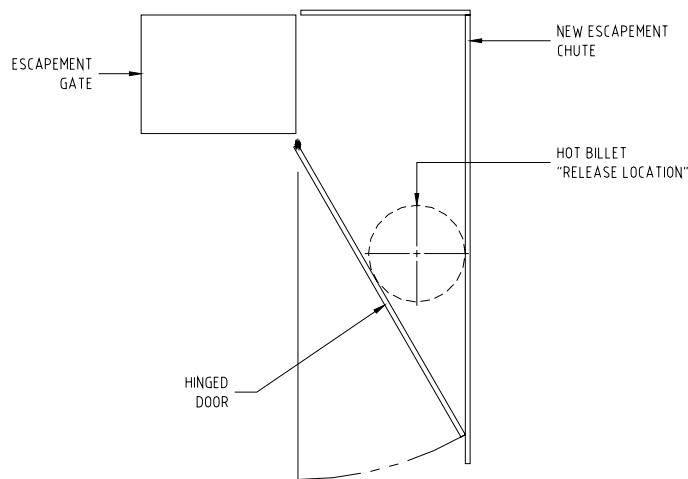

**Figure 5 - Escapement Chute concept**

At this location a sensor would activate a pneumatic cylinder that would extend the basket approximately 24 inches from its home position into the forging press pickup area. The basket assembly would contain a rolling cam that would guide and control the orientation of the basket. Toward the end of the cylinder stroke, the rolling cam would be guided such that it angles the basket toward the operator for ease of part pickup. Once the billet was removed from the basket, a sensor or switch would activate the pneumatic cylinder to return it to its home position and be ready for the next billet to fall from the escapement chute, thus repeating the process over again. Figure 6 displays a cross sectional view of the overall layout of the system and identifies a few key parts as described above.



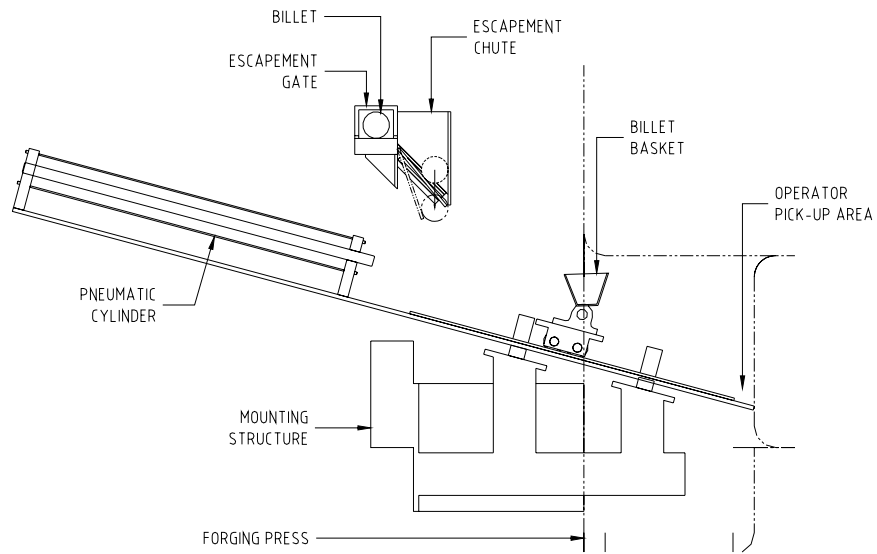

**Figure 6 - Overall system layout – Concept #2**

## **A. Timeline**

The timeline for this project (see Figure 7) will be monitored and followed to ensure the project is completed in a timely manner. Microsoft Project is being utilized to identify major milestones and to track the timelines of action items/task necessary to complete this project. Each team member has been assigned to the various tasks and this can be seen within the attached Gantt chart. The overall timeline is broken down into four major sections. Each section will be discussed below.

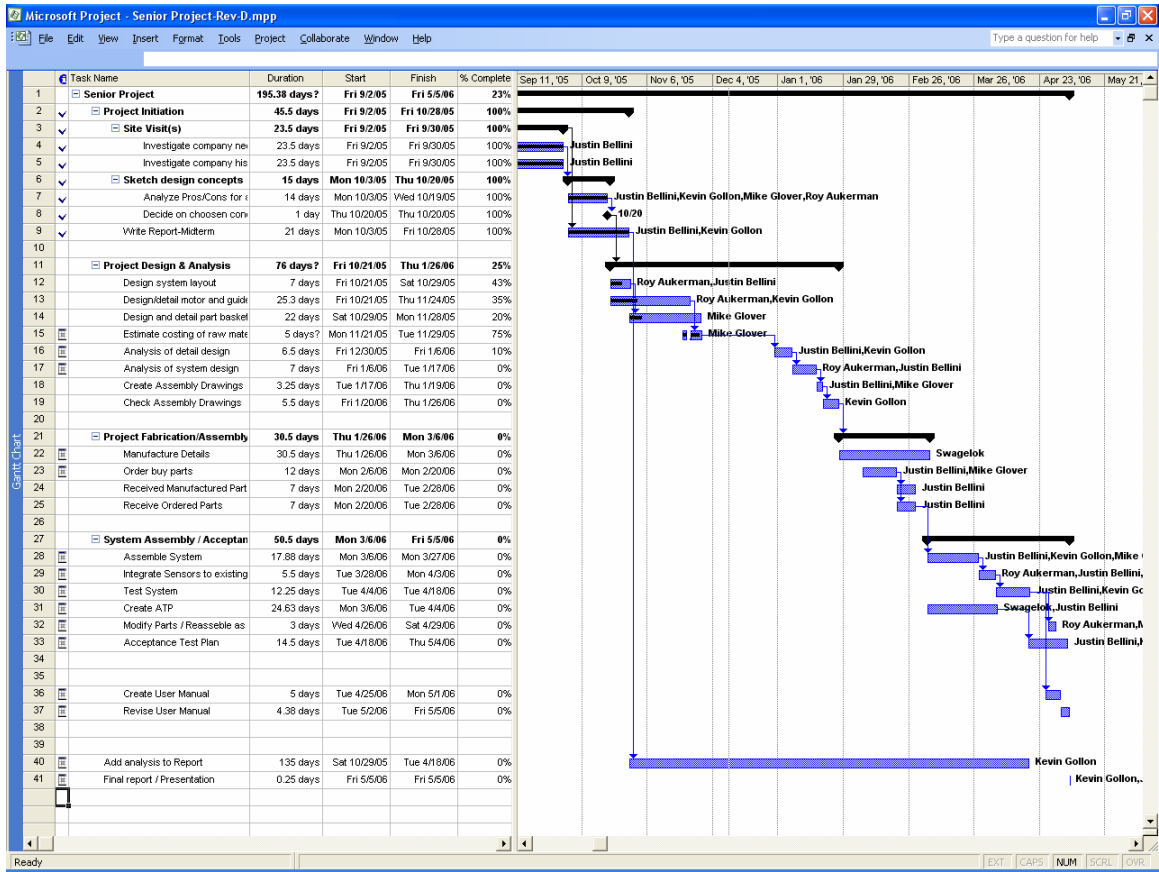

Figure 7 - Project Gantt chart

## **1. Project Initiation**

The project initiation required the design team to perform an on site visit at Swagelok Company to investigate the company's needs and concerns. Once this was performed and the problem was identified, an initial "brainstorming" session took place to discuss possible design solutions with all the members of the team. From this "brainstorming" session, positive and negative aspects for each concept were determined and a final concept was agreed upon. All of the tasks for this portion of the timeline, including a mid-term report were completed on schedule.

## **2. Project Design & Analysis**

The design and analysis portion of this project began on October 21, 2005 and was scheduled to be complete by January 31, 2006. Eight tasks define this portion of the project. The first few related tasks, Design the System Layout and Design motor and guide track were to be completed by October 29, 2005 and November 24, 2005 respectively. These tasks were not completed on time due to the initial design layout created from early concepts drawings. The early concept drawing required the pneumatic cylinder and part basket to be mounted at a very large angle. Interference between the part basket and the forging press were found when verifying our layout drawings with the existing forging press drawings. This required the cylinder and guide track to be mounted at a smaller angle thus lowering and ultimately avoiding the top portion of

the part basket from interfering with the forging press during operation. As a result, designing the system layout, motor and guide track, consumed more time than initially estimated.

The system layout was then presented to Swagelok executives for approval. The design was highly criticized for its unnecessary complexity and it was requested that we eliminate and or modify a few areas to simplify the overall system. The first area of concern was the billet cart. There was much concern whether the operator would be able to use tongs to remove small billets from the cart. This was a major source of concern since the operator is required to perform the forging operations on the billet as quickly as possible. The cart, therefore, was viewed as a handicap in allowing the operator to perform his duties effectively. In addition, the cart was to be powered by a long (custom) pneumatic cylinder. Swagelok management viewed this long cylinder as an expensive item should it ever have to be replaced. This was considered unacceptable, and it was suggested that we investigate a simplified concept to transport the billet to the operator pickup area.

As a result of the meeting a new concept was created that employed previous details such as the escapement chute while building on the need for a simplified design.

The analysis of the system was scheduled to begin the week of December 30<sup>th</sup> and as a result of the design review meeting with Swagelok, this portion of the project had slipped to the middle of March.

### **3. Project Fabrication and Assembly**

Project fabrication and assembly was scheduled to begin April 1, 2006. The design of the escapement chute along with the door mechanism required the most development work before print details could begin. Detail drawings such as mounting brackets for the slide tray and the riser blocks for the pneumatic cylinder were completed first in order to begin the fabrication process. Work continued during the fabrication and assembly process to insure that the system mechanical parts work correctly.

### **4. System Assembly / Acceptance Test Plan**

The system assembly was scheduled to begin in late April, however, due to unanticipated time constraints, and the unavailability of the forging press to non-employees, the assembly has not taken place and Swagelok will be taking on this responsibility. The assembly of the entire system onto the forging press must minimize the duration of downtime and may require the system to be put together in various sub-assemblies, to avoid interruption of Swagelok production as much as possible. In parallel with this process, Swagelok will be required to create an acceptance test plan. The acceptance test plan will include various performance tests to verify that overall system will work safely and reliably. These tests were to be performed during the week of May 25, 2006.

## **B. Breakdown of Sub-Projects**

The design of the material handling delivery system described above, and any necessary modifications required to the existing equipment were broken down into four major sub-projects. Each sub-project is discussed in detail below.

### **1. Escapement chute design**

As stated above, the design required the escapement chute to deliver a billet into the basket in a controlled manner. This would be achieved through the use of a pneumatic cylinder that would control and/or dampen the hinged release door. This would maximize the amount of time in which the billet is simultaneously in contact with the chute wall and hinged door. In turn this would minimize the distance that the billet must fall into the basket. A dynamic analysis had been performed to optimize the required angle of the hinged door such that the release action is workable over the entire range and size of billets that are manufactured on the forging press. More detail of the analysis is provided in Section IX, however, it was determined that the damper design would not accommodate the full range of billet sizes due to the fact that it would rely heavily on having a consistent weight. Therefore, a pneumatic cylinder was utilized. Linkage was also required and was added to accommodate clearance constraints of the existing design.

## 2. **Basket design**

The original basket that the billet was to be “placed” into was to be designed such that it would not only carry the wide range of billet sizes, but also be robust enough to withstand the apparent heat transfer. Initial design concepts resulted in an angle type of basket, which utilized a two-point contact as previously described in the escapement chute design. The two-point contact would have maximized the holding capability for a wide range of sizes, while minimizing the amount of surface area contact, which ultimately would have affected the heat transfer and possible basket warping. As mentioned early this concept was unacceptable and it was determined that a simplified gravity fed tray would be sufficient to transfer the hot billet to the operator pickup area.

## 3. **Gravity fed tray**

The original basket was replaced with a gravity fed tray. The tray was mounted on a 15 degree angle that would slope toward the operator. The billet would then move under its own power toward the operator. The tray is designed to be wide enough to handle all billet sizes and incorporates a “catch” bin at the bottom portion. The “catch” bin was mounted such that it slopes toward the operator and would only be wide enough for the largest billet. This is to insure that the billet does not roll around once it has reached the operator pickup area.

#### 4. Controls and PLC integration design

The entire design and control must be integrated with the existing PLC controller. This is important because the delivery and control of the billet from the conveyor to the pickup area must be repeatable and reliable. To achieve this, our design utilizes existing proximity sensor that switch on delay. The ladder logic is shown in Figure 8 below.

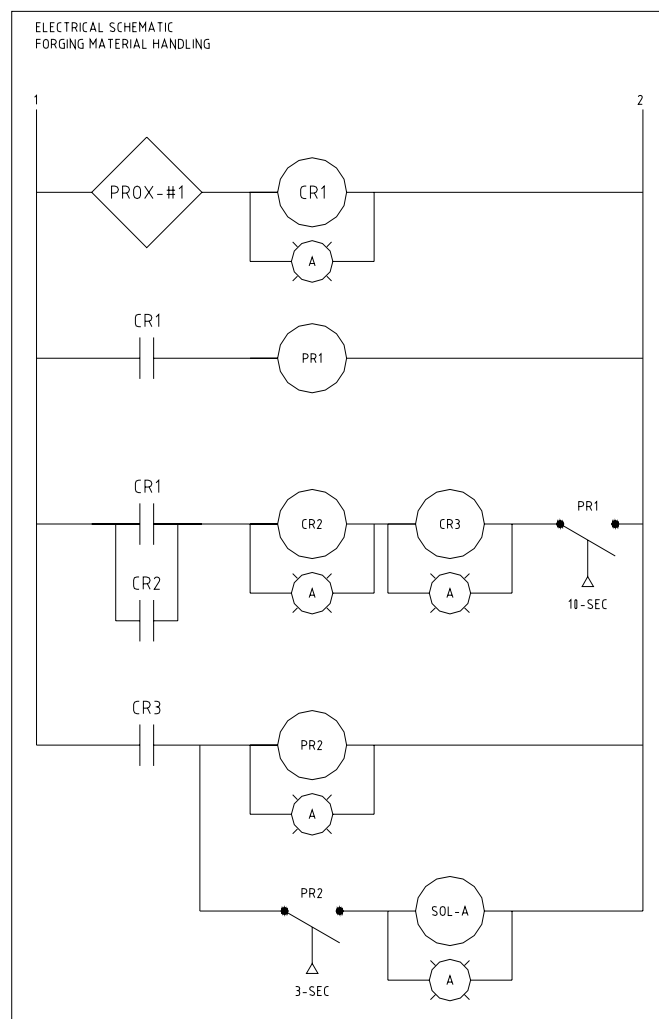
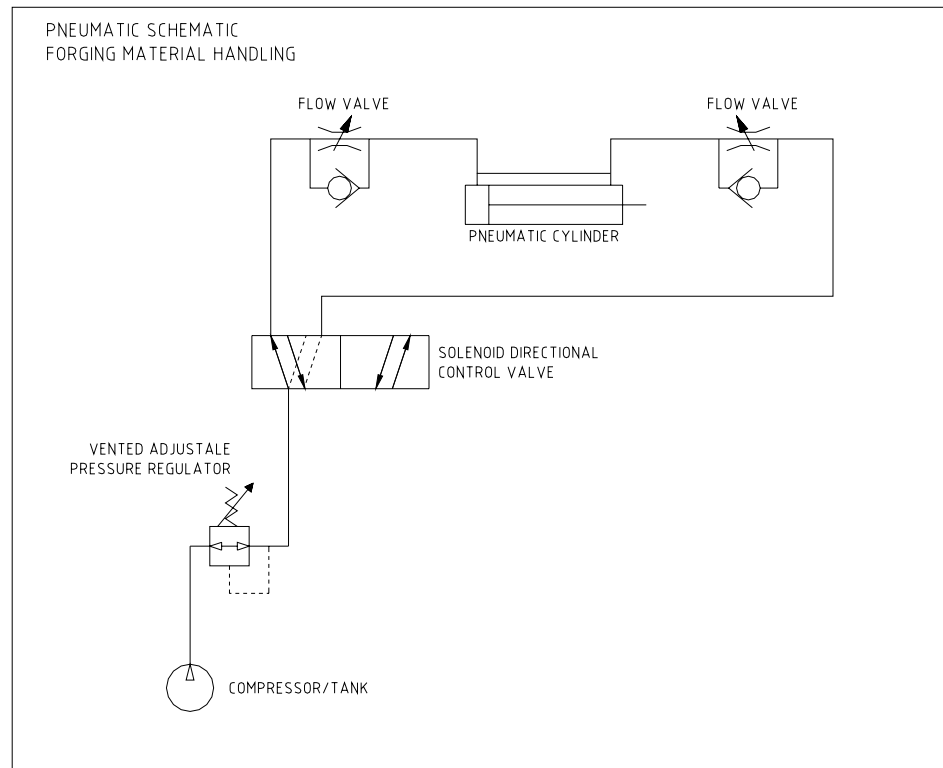

**Figure 8 - Electric schematic**

Once the billet passes the main proximity switch, a timer is engaged to activate a solenoid in 3 seconds. This solenoid activates then



activates the pneumatic cylinder, forcing the door to open. There are flow control valves on both the inlet and outlet port of the cylinder to control the speed at which the door is opened or closed. This can be seen in the Figure 9 below.



**Figure 9 - Pneumatic schematic**

The main reason for this design was that it utilized the existing proximity sensor and avoided the need to introduce “new” unproven technology. This resulted in a simpler system which is easily maintainable. Should there be a logic change that needs to occur, additional sensors could be added with minimal program changes.

## C. Cost / Return on Investment

The estimated cost for this project is based on the major components that are necessary to build, manufacture and assemble the system. Figure 10 is a tabulated chart identifying these key components and the associated costs.

<b>Mechanical Material List</b>		
<b>Part Description</b>	<b>Part Number</b>	<b>Cost</b>
Outer Guard	2006001	\$325.00
Rear Guard	2006002	\$250.00
Door, Weldment	2006003	\$150.00
Hinge, Continuous	2006004	\$25.00
Cylinder Foot mount	6471K41	\$5.00
Main Link	2006007	\$50.00
Cylinder Spacer	2006008	\$80.00
Slide Weldment / Fabrication	2006009	\$400.00
Shaft for Door	2006010	\$35.00
Clevis for Cylinder	6471K61	\$8.00
Mounting Plate	2006012	\$80.00
Side Mounting plate	2006013	\$50.00
Miscellaneous attachment parts	10000 --> 10013	\$75.00

<b>Pneumatic Material List</b>		
<b>Part Description</b>	<b>Part Number</b>	<b>Cost</b>
5 way, 2 position Control Valve	W7016A2331	\$168.00
Flow Control Valve 1/4" NPT	45045K42	\$31.00
Pressure Regulator	4957K53	\$97.00
Air Cylinder (3" stroke)	6471K11	\$28.00

<b>Electrical Material List</b>		
<b>Part Description</b>	<b>Part Number</b>	<b>Cost</b>
Control Relay	69585K85	\$20.00
Relay Socket	69585K4	\$15.00
(ON) Delay on Make Relay	7268K23	\$45.00
(OFF) Delay on Make Relay	7268K43	\$50.00
Relay Mounting Socket (8-Pin)	7122K19	\$8.00
35mm Din Rail	8961K15	\$5.00
100' 18G Stranded Wire	7587K54	\$18.00

<b>Labor Hours</b>		
<b>Activity</b>	<b>Per Hour Cost</b>	<b>Cost</b>
	20	40
		\$800.00
Total		\$2,818.00

Figure 10 - Estimated costs

Utilizing current downtime records it is clear there is tremendous inefficiency with the current system. The current system, which is running three shifts per day and six days per week, experiences approximately 6 miss-feeds to the operator pickup area per shift. It requires approximately 5 minutes of time to correct for each miss-feed. Over the span of one week this equals approximately 7.5 hours of lost productivity. When multiplied by the current hourly wage of \$150, there is a loss of \$1,125 per week.

The new design will eliminate this downtime to correct for each miss-feed made to the operator pickup area. With a total investment of \$2,818, the system will have a repayment time of approximately 2 ½ weeks. More importantly, the new system will produce a yearly savings of approximately \$56,250.

## IX. Analysis and Modeling

There are two major areas of the material handling delivery system, which need to be analyzed to optimize its performance and function. Each area will be discussed in detail below.

### 1. Chute door Kinematic analysis

Early concepts of the escapement chute door relied upon a damper cylinder. As result, the chute door would depend heavily on the specific size of billet and the mounting angle,  $\theta$ , as well as the angular acceleration,  $\alpha$ , and angular velocity,  $\omega$ . To optimize the function of the door our analysis determined the angular velocity and angular acceleration as a function of the mounting angle,  $\theta$ . The resulting information was to assist in sizing the proper cylinder and its final location. The analysis was performed symbolically and is detailed below. Refer to Figure 11, which displays the schematic drawing utilized to perform this analysis.

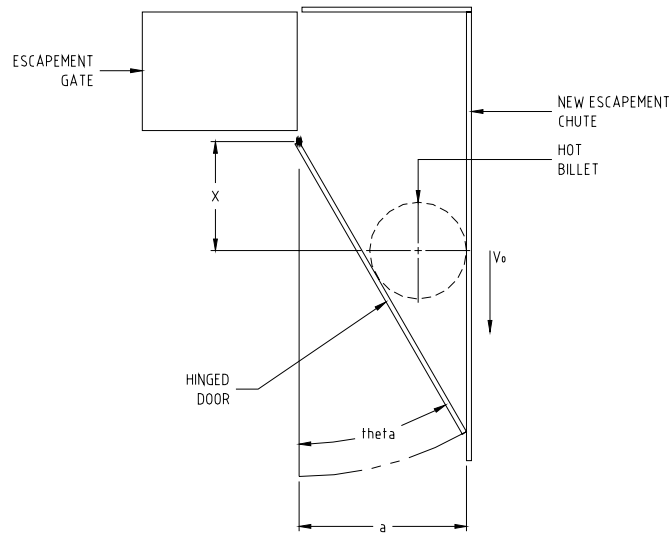

**Figure 11 - Schematic drawing for analysis**

The position equation is defined as,

$$x = a * (\cot \theta) \quad \text{Eqn. 1.}$$

Performing the time derivative of the above equation yields,

$$\frac{dx}{dt} = -a(\csc^2 \theta) \theta \frac{d\theta}{dt} \quad \text{Eqn. 2.}$$

Noting that

$$\frac{dx}{dt} = v_o \quad \text{Eqn. 3.}$$

and

$$\frac{d\theta}{dt} = -\omega \quad \text{Eqn. 4.}$$

Substituting equations 3 and 4 into equation 2 will yield,

$$v_o = -a(\csc^2 \theta)(-\omega) \quad \text{Eqn. 5.}$$

Rearranging equation 5 results in the angular velocity of the door defined as,

$$\omega = \frac{v_o}{a(\csc^2 \theta)} \quad \text{Eqn. 6.}$$

or,

$$\omega = \frac{v_o}{a} (\sin^2 \theta) \quad \text{Eqn. 7.}$$

The angular acceleration is performed in a similar manner. From equation 6,

$$\alpha = \frac{d\omega}{d\theta} \quad \text{Eqn. 8.}$$

Expanding and substituting yields,

$$\alpha = \frac{v_o}{a} ((2)(\sin \theta)(\cos \theta)) \frac{d\theta}{dt} \quad \text{Eqn. 9.}$$

Noting that,

$$2 \sin \theta \cos \theta = \sin 2\theta \quad \text{and} \quad \omega = \frac{d\theta}{dt} = \frac{v_o}{a} \sin^2 \theta$$

substituting results in the angular acceleration of the door defined as,

$$\alpha = \frac{v_o}{a} \sin 2\theta \left( \frac{v_o}{a} \sin^2 \theta \right) \quad \text{Eqn. 10.}$$

or,

$$\alpha = \frac{v_o^2}{a^2} \sin 2\theta \sin^2 \theta \quad \text{Eqn. 11.}$$

Equation 7 and equation 11 will now be utilized to calculate the velocity and accelerations for specific mounting angles of the trap door. This process is ongoing and will continue as described and noted in the project Gantt chart.

We did not use these results as they proved unrealistic for all ranges of billet sizes. Therefore, the decision was made to control the door pneumatically. Due to space constraints we determined the position of the pneumatic cylinder and the location of the chute door was already known. Therefore, the required linkage was determined graphically and is shown in Figure 12. The graphical linkage synthesis also confirms that the escapement door will function properly. Position one which is the initial position is shown in black while position two is shown in red.

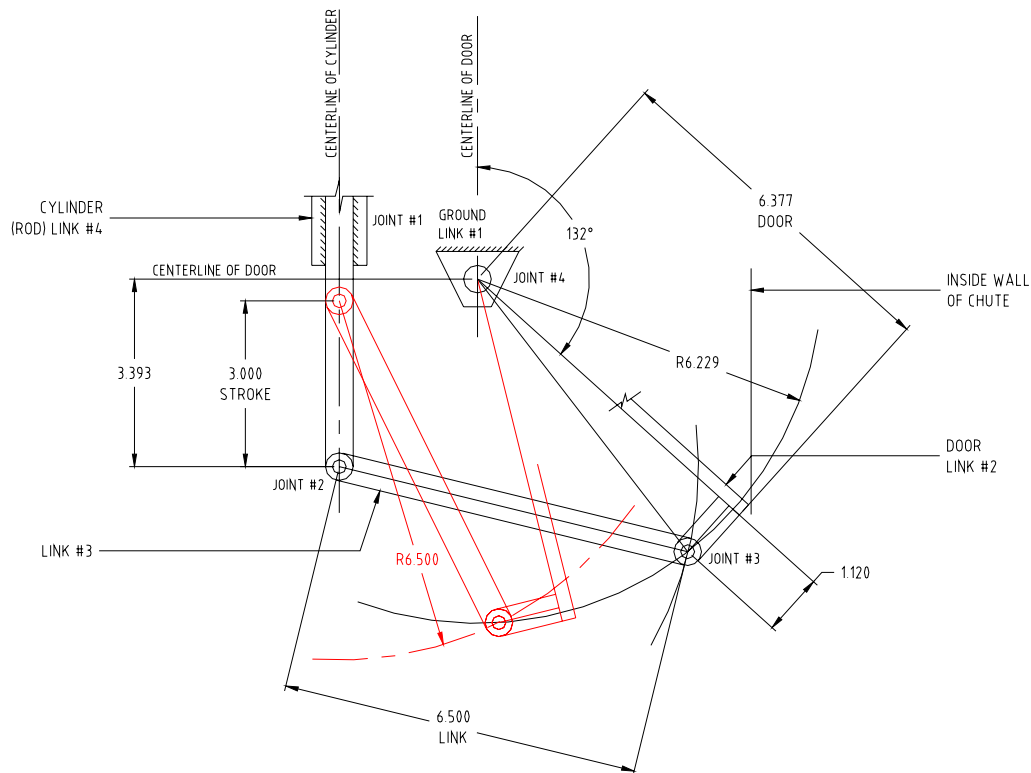

**Figure 12 - Graphical Linkage Analysis**

## 2. Chute door thermal analysis

In addition to the linkage design it was necessary to account for the extreme temperatures in which the door would experience. To avoid possible warping of the door, an insulator was added and fastened to the inside of the door. To solve this issue, the design required a material with a low value of thermal conductivity. This was found using alumina board, a non-brittle material. It has a thermal conductivity value of 1.2 Btu-in/hr-ft<sup>2</sup> F and is able to work within a temperature range of -120 F to +2700 F.

Adding a ¼” thick piece as shown in Figure 13, a few heat transfer calculations can be determine the amount of heat the steel hinged door would experience.



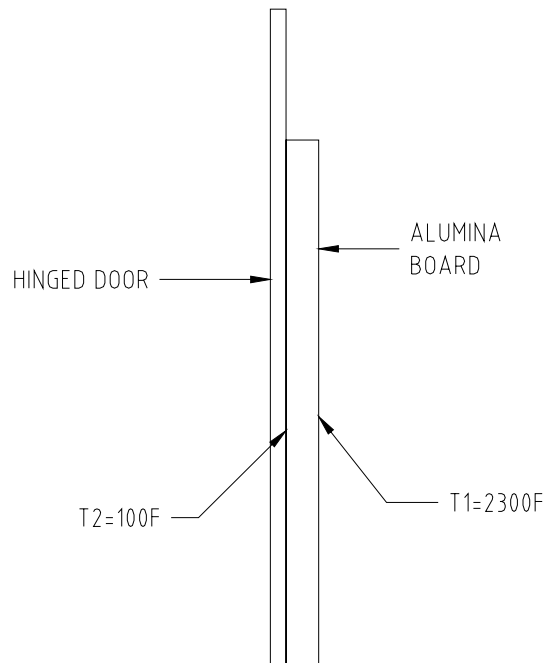

**Figure 13 - Thermal insulation**

Assuming a steady state condition as the worse case situation, as opposed to the transient analysis, the following relationship applies,

$$q = kA \frac{\Delta T}{\Delta x}$$

Substituting the appropriate values in SI units, results in,

$$q = (2.46)(.000645) \left( \frac{1260 - 38}{.00635} \right)$$

This assumes a very small area of contact due to the door making a tangential contact with the hot billet. The result is 306 Watts of heat transferred to the door. This is considerable less than what the hinged door would experience without insulation and as a result, it should prevents the hinged door from warping over time.

To account for the radiate effect the escapement chute will be manufactured out of expanded metal to minimize the amount of heat trapped within the chute area.

## **X. Summary**

As stated in the beginning of this report, this design project examined and solved a manufacturing process problem which was costing the Swagelok Corporation time, money, and most importantly, the safety of its workers. It involved examining the current system, which was found to be extremely inadequate, from an entirely different perspective and conceptualizing a new solution which introduced control and reliability. This system was then revised and improved upon through collaboration until the final design was achieved. The result was an extremely simple system which is not only cost effective to implement, but improved the safety and dependability of the overall system. The return on this investment will not only allow the employees to become more productive, but will experience a net savings of approximately \$56,000. Overall, it is clear that this design project has been a success.

## **XI. Appendix A**

This portion of the report includes the assembly and detail drawing used to obtain quotes for fabrication and assembly.

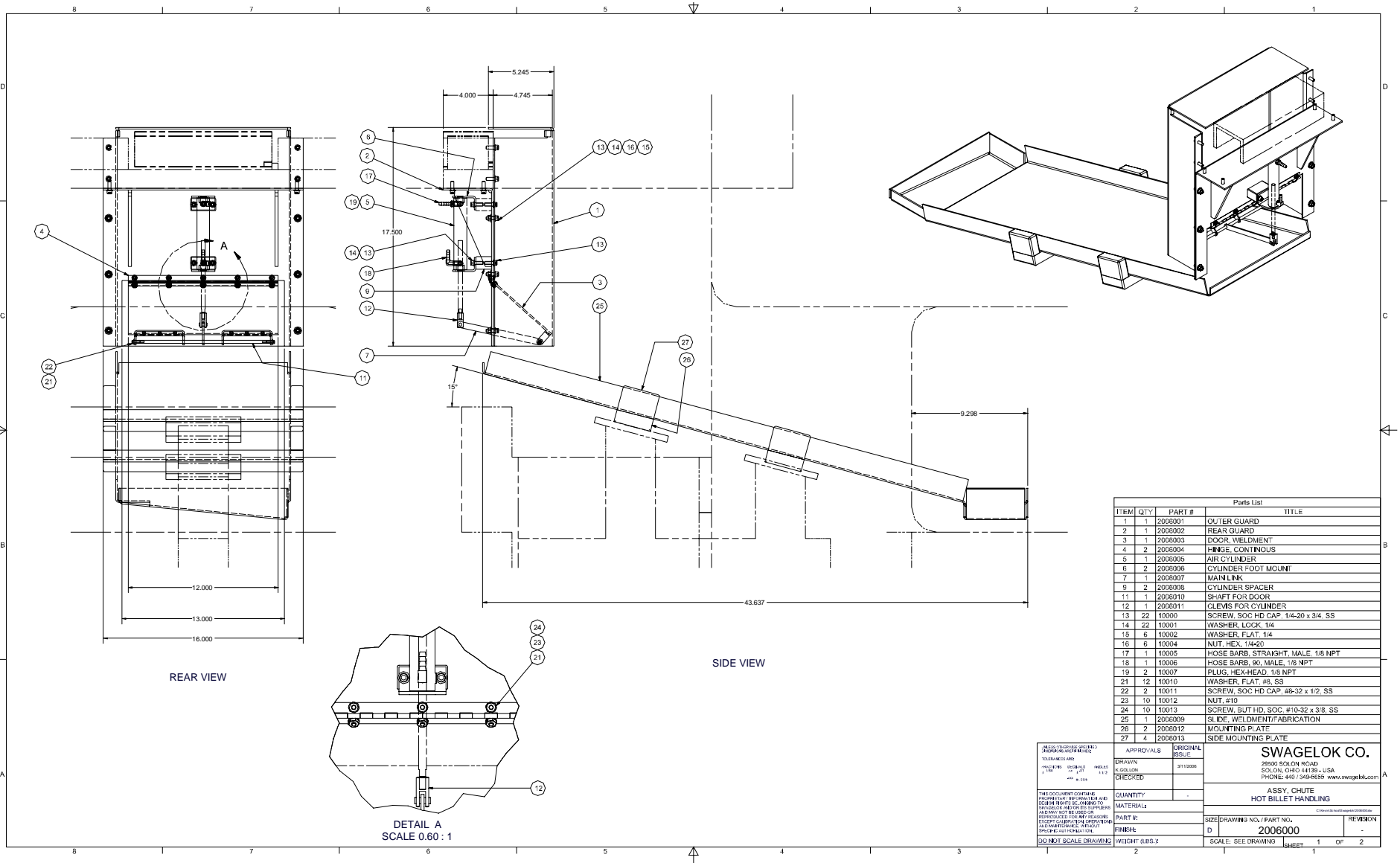

ITEM	QTY	PART #	TITLE
1	1	2006001	OUTER GUARD
2	1	2006002	REAR GUARD
3	1	2006003	DOOR WELDMENT
4	2	2006004	HINGE, CONTINUOUS
5	1	2006005	AIR CYLINDER
6	2	2006006	CYLINDER FOOT MOUNT
7	1	2006007	MAIN LINK
9	2	2006008	CYLINDER SPACER
11	1	2006010	SHAFT FOR DOOR
12	1	2006011	GLEYS FOR CYLINDER
13	22	10000	SCREW, SOC HD CAP, 1/4-20 x 3/4, SS
14	22	10001	WASHER, LOCK, 1/4
15	6	10002	WASHER, FLAT, 1/4
16	6	10004	NUT, HEX, 1/4-20
17	1	10005	HOSE BARB, STRAIGHT, MALE, 1/8 NPT
18	1	10006	HOSE BARB, 90, MALE, 1/8 NPT
19	2	10007	PLUG, HEX-HEAD, 1/8 NPT
21	12	10010	WASHER, FLAT, #8, SS
22	2	10011	SCREW, SOC HD CAP, #8-32 x 1/2, SS
23	10	10012	NUT, #10
24	10	10013	SCREW, BUT HD, SOC, #10-32 x 3/8, SS
25	1	2006009	SLIDE WELDMENT/FABRICATION
26	2	2006012	MOUNTING PLATE
27	4	2006013	SIDE MOUNTING PLATE

ALL DIMENSIONS UNLESS OTHERWISE SPECIFIED ARE IN INCHES.  
TOLERANCES ARE:  
FRACTIONS DECIMALS MILLI  
1/16" 0.0157 0.127 1.175  
0.005 0.0005

THIS DOCUMENT CONTAINS PROPRIETARY INFORMATION AND IS THE PROPERTY OF SWAGelok CO. IT IS TO BE KEPT CONFIDENTIAL AND NOT TO BE REPRODUCED OR TRANSMITTED IN ANY FORM OR BY ANY MEANS, ELECTRONIC OR MECHANICAL, INCLUDING PHOTOCOPYING, RECORDING, OR BY ANY INFORMATION STORAGE AND RETRIEVAL SYSTEM.

DO NOT SCALE DRAWINGS

APPROVALS  
DRAWN BY: JLS/JLN  
CHECKED BY: JLS/JLN

QUANTITY: -  
MATERIAL: -  
PART #: -  
FINISH: -  
WEIGHT (LBS.): -

ORIGINAL ISSUE: 01/19/08

**SWAGelok CO.**  
2850 SOLOON ROAD  
SOLOON, OHIO 44130-4 USA  
PHONE: 440.326.8855 www.swagelok.com

ASSY. CHUTE  
HOT BILLET HANDLING

SEE DRAWING NO. / PART NO.:  
D 2006000

REVISION: -

SCALE: SEE DRAWING SHEET 1 OF 2

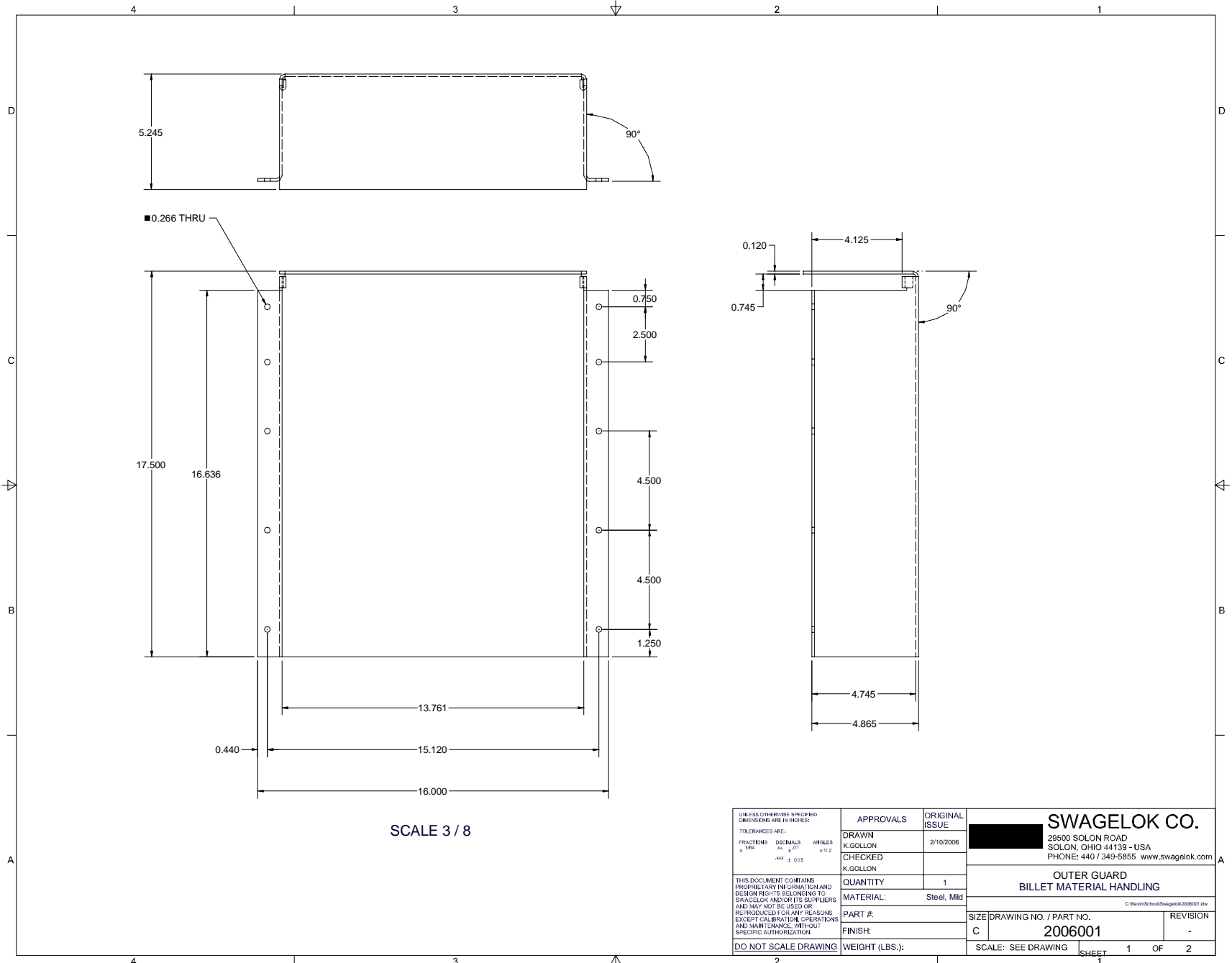

SCALE 3 / 8

<small>UNLESS OTHERWISE SPECIFIED DIMENSIONS ARE IN INCHES</small> <small>TOLERANCES ARE:</small> <small>FRACTIONS DECIMALS ANGLES</small> <small>± 1/64 ± 0.001 ± 1/2</small> <small>± 0.005 ± 0.005 ± 0.12</small>	APPROVALS	ORIGINAL ISSUE	<b>SWAGELOK CO.</b> 29500 SOLON ROAD SOLON, OHIO 44139 - USA PHONE: 440 / 349-5855 www.swagelok.com	
	DRAWN K.GOLLON CHECKED K.GOLLON	2/10/2006		
<small>THIS DOCUMENT CONTAINS PROPRIETARY INFORMATION AND DESIGN RIGHTS BELONGING TO SWAGELOK AND/OR ITS SUPPLIERS AND MAY NOT BE USED OR REPRODUCED FOR ANY REASONS EXCEPT CALIBRATION OPERATIONS AND MAINTENANCE, WITHOUT SPECIFIC AUTHORIZATION.</small> <b>DO NOT SCALE DRAWING</b>	QUANTITY	1	OUTER GUARD BILLET MATERIAL HANDLING <small>© Warrick School Swagelok 2006/001.dwg</small>	
	MATERIAL:	Steel, Mkd		
	PART #:		SIZE	DRAWING NO. / PART NO.
	FINISH:		C	2006001
	WEIGHT (LBS.):		SCALE: SEE DRAWING	
			SHEET 1 OF 2	

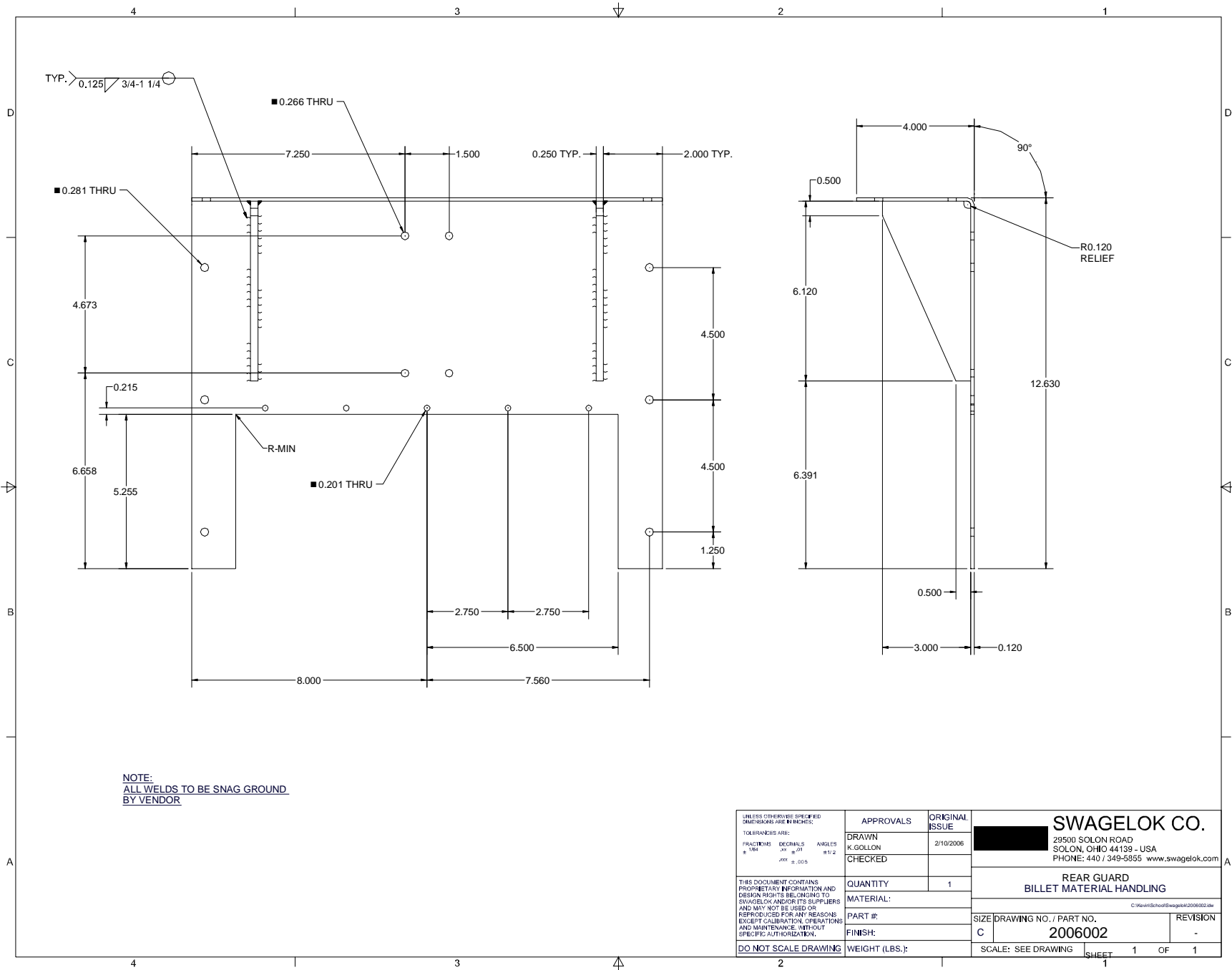

**NOTE:**  
ALL WELDS TO BE SNAG GROUND  
BY VENDOR

<small>UNLESS OTHERWISE SPECIFIED DIMENSIONS ARE IN INCHES:</small> <small>TOLERANCES ARE:</small> <small>FRACTIONS: ± 1/64</small> <small>DECIMALS: ± .01</small> <small>ANGLES: ± 1/2</small> <small>WELDS: ± .005</small>	APPROVALS	ORIGINAL ISSUE	<b>SWAGELOK CO.</b> 29500 SOLON ROAD SOLON, OHIO 44139 - USA PHONE: 440 / 349-5855 www.swagelok.com
	DRAWN K.GOLLON	2/10/2006	
<small>THIS DOCUMENT CONTAINS PROPRIETARY INFORMATION AND DESIGN RIGHTS BELONGING TO SWAGELOK AND/OR ITS SUPPLIERS AND MAY NOT BE USED OR REPRODUCED FOR ANY REASONS EXCEPT CALIBRATION, OPERATIONS AND MAINTENANCE WITHOUT SPECIFIC AUTHORIZATION.</small> <b>DO NOT SCALE DRAWING</b>	CHECKED		<b>REAR GUARD</b> <b>BILLET MATERIAL HANDLING</b>
	QUANTITY	1	<small>© WeirSchoofSwagelok200602.doc</small>
	MATERIAL:		SIZE DRAWING NO. / PART NO. <b>C 2006002</b>
	PART #:		REVISION -
FINISH:		SCALE: SEE DRAWING	
WEIGHT (LBS.):		SHEET 1 OF 1	

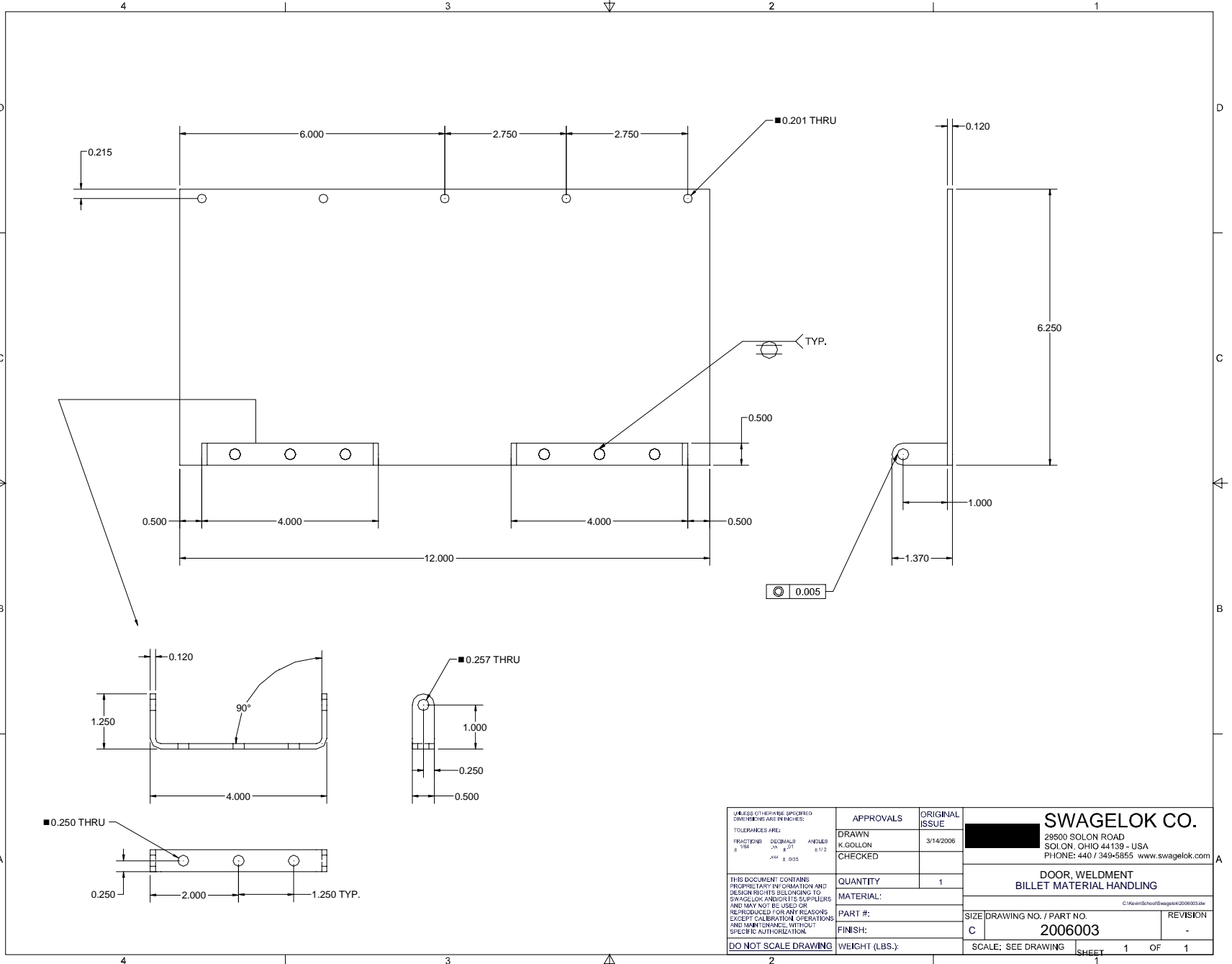

<small>UNLESS OTHERWISE SPECIFIED DIMENSIONS ARE IN INCHES.</small> <small>TOLERANCES ARE:          FRACTIONS DECIMALS ANGLES  <math>\pm .004</math> <math>\pm .01</math> <math>\pm 1/2</math>  <math>\pm .005</math> </small>	<b>APPROVALS</b> DRAWN K.GOLLON CHECKED	<b>ORIGINAL ISSUE</b> 3/14/2006	<b>SWAGELOK CO.</b> 29500 SOLON ROAD SOLON, OHIO 44139 - USA PHONE: 440 / 349-5855 www.swagelok.com
	<small>THIS DOCUMENT CONTAINS          PROPRIETARY INFORMATION AND          DESIGN RIGHTS BELONGING TO          SWAGELOK AND ITS SUPPLIERS          AND MAY NOT BE USED OR          REPRODUCED FOR ANY REASONS          EXCEPT CALIBRATION OPERATIONS          AND MAINTENANCE, WITHOUT          SPECIFIC AUTHORIZATION.</small> <b>DO NOT SCALE DRAWING</b>	<b>QUANTITY</b> 1	
<b>PART #:</b> FINISH:		<b>SIZE</b> DRAWING NO. / PART NO. C 2006003	<small>REVISION</small> -
<b>WEIGHT (LBS.):</b>		<b>SCALE:</b> SEE DRAWING	SHEET 1 OF 1



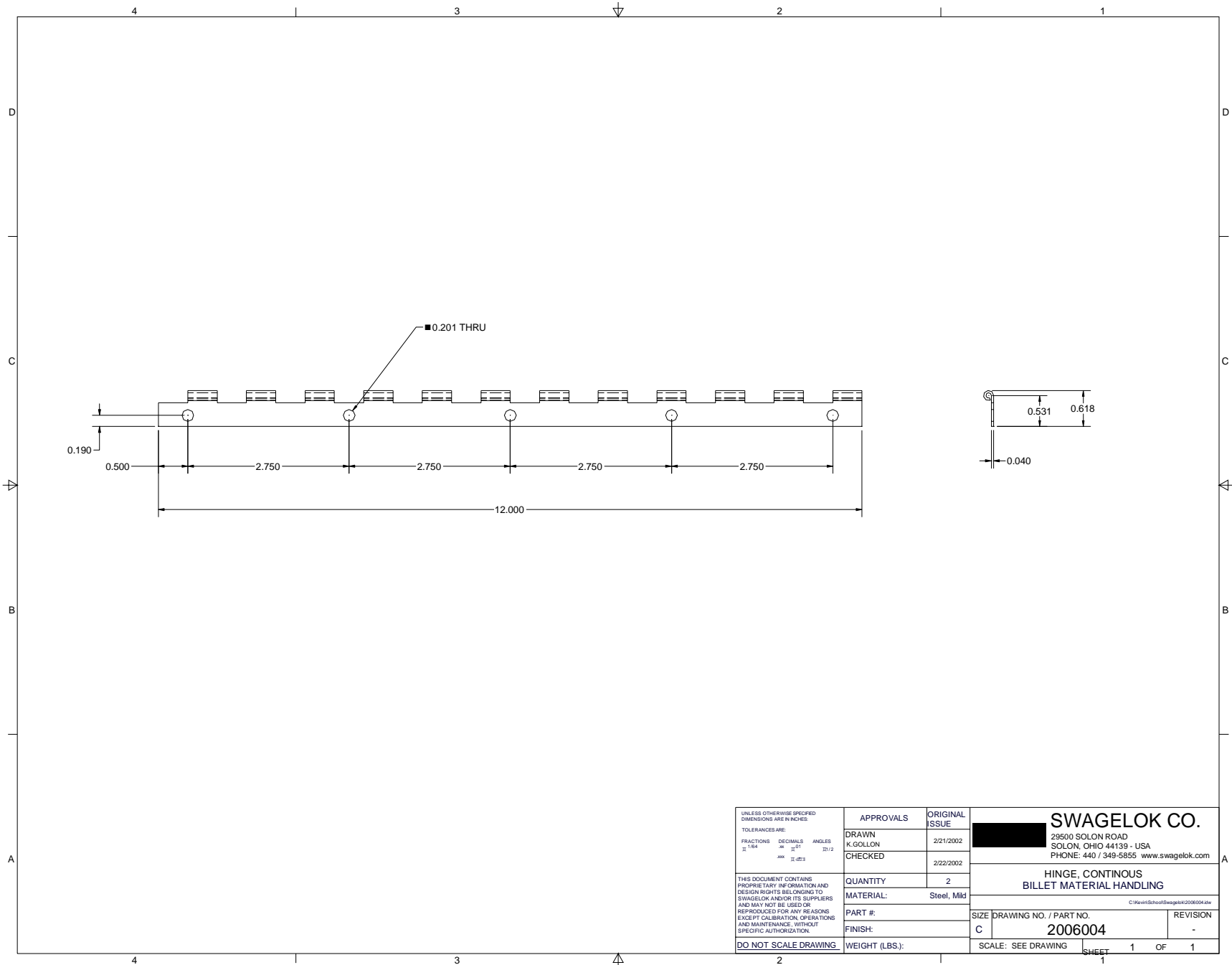

UNLESS OTHERWISE SPECIFIED DIMENSIONS ARE IN INCHES  TOLERANCES ARE: FRACTIONS    DECIMALS    ANGLES II 1/64    .001    II .01    III 1/2 .005    .0025	APPROVALS	ORIGINAL ISSUE	<b>SWAGELOK CO.</b> 29500 SOLON ROAD SOLON, OHIO 44139 - USA PHONE: 440 / 349-5855 www.swagelok.com
	DRAWN K.GOLLON	2/21/2002	
THIS DOCUMENT CONTAINS PROPRIETARY INFORMATION AND DESIGN RIGHTS BELONGING TO SWAGELOK AND/OR ITS SUPPLIERS AND MAY NOT BE USED OR REPRODUCED FOR ANY REASONS EXCEPT CALIBRATION, OPERATIONS AND MAINTENANCE, WITHOUT SPECIFIC AUTHORIZATION.	CHECKED	2/22/2002	HINGE, CONTINUOUS BILLET MATERIAL HANDLING
	QUANTITY	2	DRAWING NO. / PART NO. <b>2006004</b>
	MATERIAL:	Steel, Mild	REVISION
	DO NOT SCALE DRAWING	WEIGHT (LBS.):	SCALE: SEE DRAWING

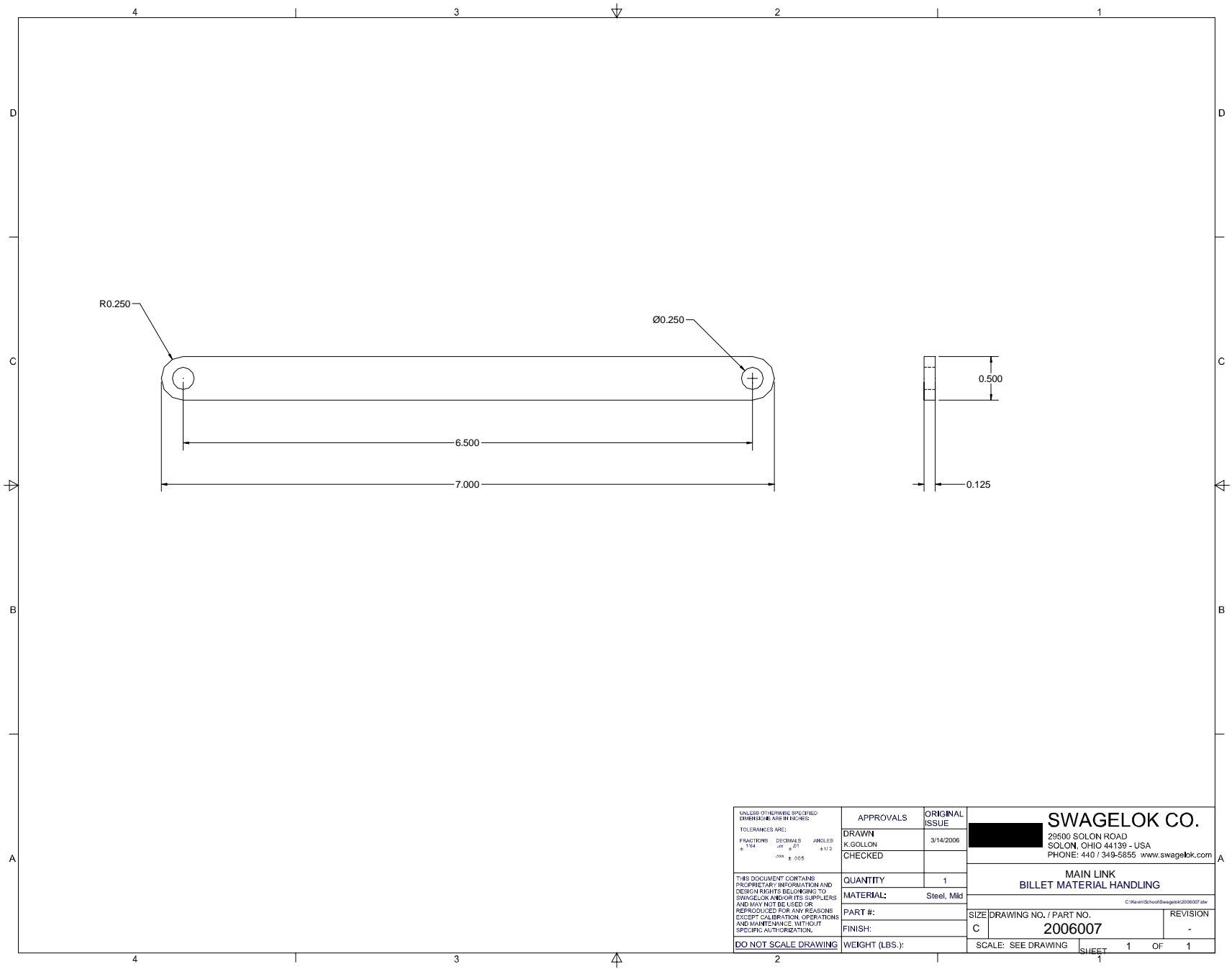

UNLESS OTHERWISE SPECIFIED DIMENSIONS ARE IN INCHES  TOLERANCES ARE: FRACTIONS    DECIMALS    ANGLES $\pm \frac{1}{64}$ $\pm .01$ $\pm 1/2$ $\pm .005$	APPROVALS	ORIGINAL ISSUE	<b>SWAGELOK CO.</b> 29500 SOLON ROAD SOLON, OHIO 44139 - USA PHONE: 440 / 349-5855 www.swagek.com
	DRAWN K.GOLLON CHECKED	3/14/2006	
THIS DOCUMENT CONTAINS PROPRIETARY INFORMATION AND DESIGN RIGHTS BELONGING TO SWAGELOK AND/OR ITS SUPPLIERS AND MAY NOT BE USED OR REPRODUCED FOR ANY REASONS EXCEPT CALIBRATION, OPERATIONS AND MAINTENANCE WITHOUT SPECIFIC AUTHORIZATION. <b>DO NOT SCALE DRAWING</b>	QUANTITY 1	MATERIAL: Steel, Mild	MAIN LINK BILLET MATERIAL HANDLING <small>C:\Kwin\School\Swagek\2006007.dwg</small>
	PART #: FINISH:	SCALE: SEE DRAWING	SIZE DRAWING NO. / PART NO. C / <b>2006007</b>
	WEIGHT (LBS.):	SHEET 1 OF 1	REVISION -

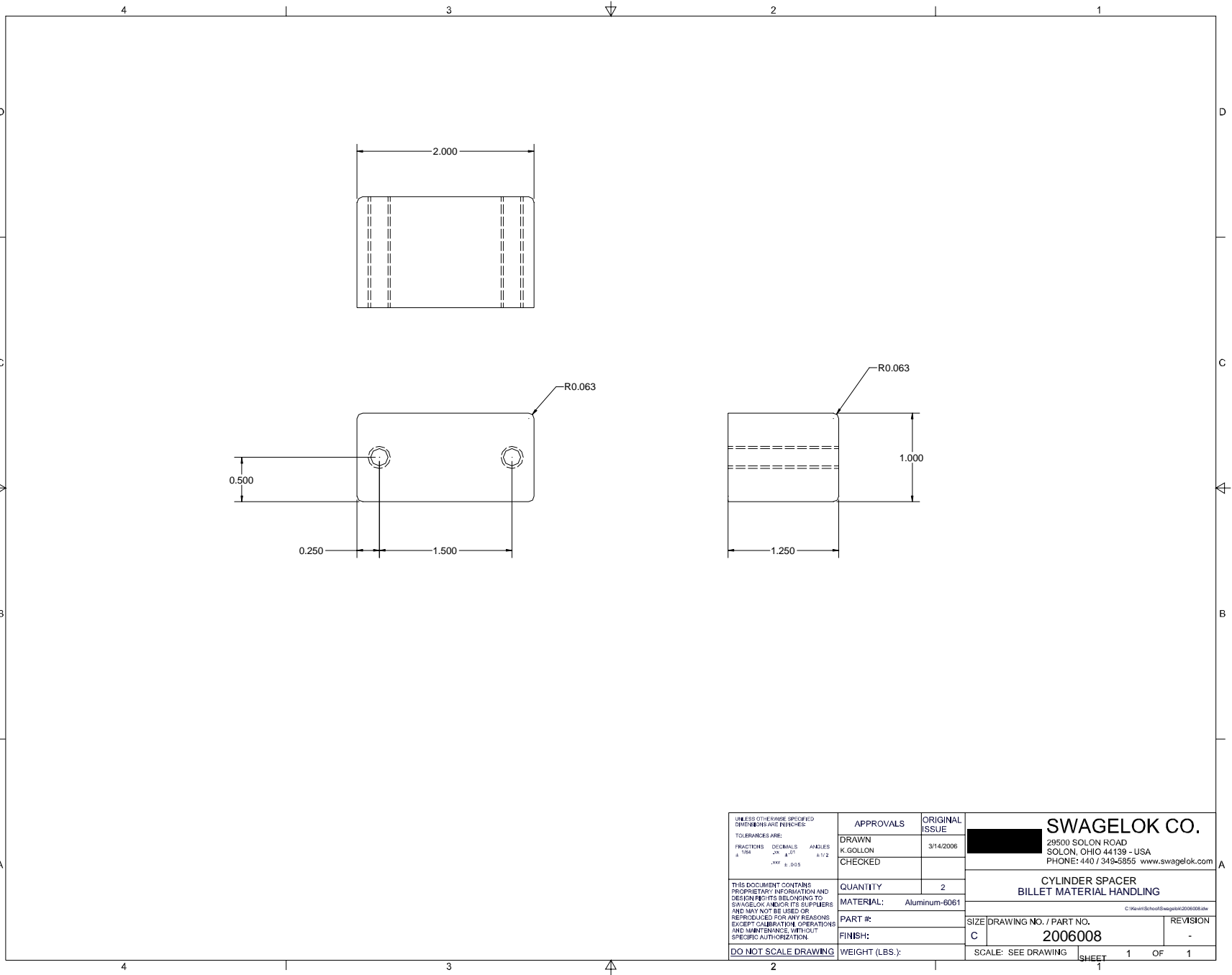

<small>UNLESS OTHERWISE SPECIFIED DIMENSIONS ARE IN INCHES</small> <small>TOLERANCES ARE:</small> <small>FRACTIONS DECIMALS ANGLES</small> <small>± .004 ± .005 ± .012</small>	<small>APPROVALS</small> <small>DRAWN</small> <small>K. GOLLON</small> <small>CHECKED</small>	<small>ORIGINAL ISSUE</small> <small>3/14/2006</small>	<b>SWAGelok CO.</b> 29500 SOLON ROAD SOLON, OHIO 44139 - USA PHONE: 440 / 349-5855 www.swagelok.com	
	<small>THIS DOCUMENT CONTAINS PROPRIETARY INFORMATION AND DESIGN RIGHTS BELONGING TO SWAGelok AND/OR ITS SUPPLIERS AND MAY NOT BE USED OR REPRODUCED FOR ANY REASONS EXCEPT CALIBRATION OPERATIONS AND MAINTENANCE WITHOUT SPECIFIC AUTHORIZATION.</small> <b>DO NOT SCALE DRAWING</b>	<small>QUANTITY</small> 2		<small>MATERIAL:</small> Aluminum-6061
<small>WEIGHT (LBS.):</small>		<small>SCALE: SEE DRAWING</small>		SHEET 1 OF 1



