

# Theory & Applications of Forging & Die Design

FORGING INDUSTRY ASSOCIATION  
OFFICIAL EDUCATION COURSE

## MODULES INCLUDE:

- Process of Forging
- Factors Affecting the Forging Process
- Mechanical Behavior of Metals
- Stress Encountered in Forging
- Physics Fundamentals
- Forging Die Failures
- Mechanical Fundamentals
- Forging Equipment
- Forging Operations
- Simulation Software
- Die Block Design
- Impression Die Forging

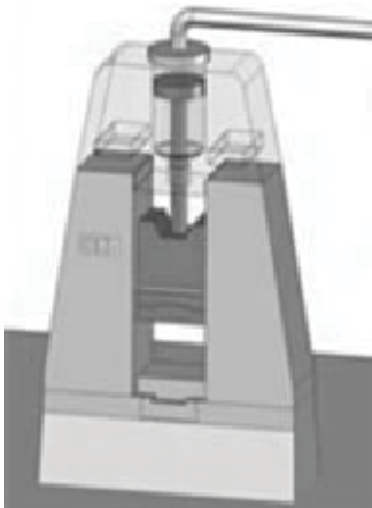
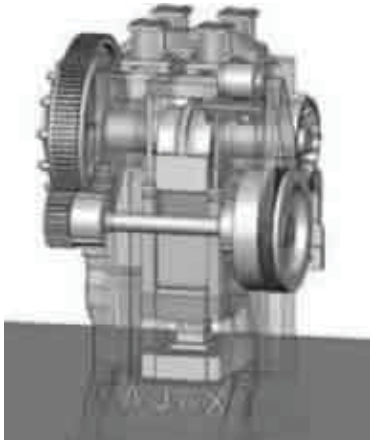

## *41<sup>st</sup> Presentation*

*The "Theory & Applications of Forging & Die Design" school continues to evolve, reflecting new insights into forging technology and the wide availability of metal flow simulation software. This four-day school is taught by a team of industry experts and engineering professors who work together to carefully explain principles and practice. We urge you to join the 1300+ forging employees who have already attended this course.*

*Scheduled for one presentation  
in 2010*

***June 14 – 17, 2010***

Residence Inn - Marriott Cleveland  
Prospect Ave., Cleveland, OH

***Dr. Chester J. Van Tyne, FIERF Professor, Colorado  
School of Mines, Curriculum Coordinator***

# SCHOOL OVERVIEW

## ***Process of Forging***

Forging is a method of shaping metals and alloys into parts of useful shapes. It is an art that has developed over thousands of years. It is still developing. Because of its long history, many of the terms used reflect ancient practices, and some of them have lost their original meaning. Therefore, we will establish a common language by reviewing all forging processes for which dies will have to be designed.

## ***Factors Affecting the Forging Process***

When a die designer receives a request for a die, they follow an extremely complex process in which a variety of factors are weighed, their interactions considered and, if necessary, several interactions performed to arrive at a solution. We will review some of these interactions and show how to quantify many aspects of die design.

## ***Mechanical Behavior of Metals***

The deformation of the workpiece may be expressed numerically by its dimensions before and after forging. The shape change and its effects are thus easily described by strain to which the material is subjected.

## ***Stress Encountered in Forging***

Flow stress is a fundamental metal characteristic of great importance. It is the stress, which must be applied to make a metal deform plastically.

## ***Predicting Forging Loads: Simple Upsetting***

Often approximate values for forging loads can be determined by assuming simple shapes for the work pieces. The upsetting of cylinders and forging of slabs with flat dies will be presented.

## ***Predicting Forging Loads: Impression Die Forging***

In forging, metal flow, die fill and forging load are largely determined by; (a) the resistance of the forging material to flow, (b) the friction and cooling effects at the die-material interface, and (c) the complexity of the forging shape. These issues will be discussed.

## ***Mechanical Fundamentals***

Stress and strain are critical concepts in understanding how the metal behaviors under the influence of the die. At low temperatures metals become stronger as more deformation is imposed. At high temperatures the rate of deformation strongly influences the metal's resistance to flow. Die deflection is also dependent on the stresses generated during the forging.

## ***Physics Fundamentals***

The concepts of force, energy, work and power are important in producing a successful forging and using forging equipment effectively. All these entities are related to each other, yet each needs to be understood separately and how it can be harnessed within a forging operation.

## ***Forging Materials***

Forging can produce practically all important metals and alloys. There can be, however, great differences in their flow strength and their workability. Even for the same material, these properties may also greatly change with temperature, strain rate, and the cleanliness of the material.

## ***Contact Fundamentals***

The interface between the die and the workpiece is important for frictional resistance. Friction is a very powerful controlling factor in forging. Lubrication is often required to control the friction, reduce die wear, prevent welding and aid in part removal.

## ***Thermal Fundamentals***

Heat can be transferred by conduction, convection or radiation. All three modes of heat flow are present in a forging operation. It is important to understand the dominant mode so that energy can be effectively used in heating the workpiece up to the proper forging temperature.

## ***Forging Operations***

Closed die forging, open die forging, extrusion, drawing, rolling, shearing and trimming are operations used in producing high quality forgings. These operations have some similarities but also significant differences. It is important to understand some of the design details associated with each operation.

## ***Forging Equipment***

Forging hammers, mechanical presses, hydraulic presses and screw presses are all used in forge shops. The behavior and limitations of each piece of equipment is critical in using the proper equipment for the appropriate job.

## ***Simulation Software***

The current standard for metalforming simulations include robust and thoroughly validated process models, which are fast, cost effective and relatively easy to use. Designers and engineers can run simulations in even small companies on their personal computers.

## ***Forging Defects***

Geometrical and material induced defects can occur during forging. Geometrical defects can be corrected by changes in die design. Material defects can be minimized by forging under the right conditions.

## ***Forging Die Failures***

Forging dies can fail in service. Such failures are undesirable. When a failure does occur, it is important that the root cause for the failure be found and the conditions for the failure be avoided or minimized in the future.

# SCHOOL OVERVIEW CONTINUED

## ***Preforming for Impression Die Forging***

One of the most important aspects of impression die forging is the proper design of preforming operations and of the blocker dies, to achieve adequate metal distribution. Thus, in the finish-forging operation, defect-free metal flow and complete die filling can be achieved and metal losses into the flash can be minimized.

## ***Impression Die Forging***

The die designer's goal is to produce a closed die forging at the lowest cost that has the physical and mechanical properties necessary to meet the customer's requirements. To attain the goal, the designer must consider those factors that govern metal flow and die filling so as to produce defect free parts with the required properties.

## ***Die Block Design***

Hammer and press die differences, die block sizes, die inserts, die shanks and holders, location of die stations and multiple impression dies are features that will be presented.

## ***Trimming, Special Processes***

In this section we will cover plastic deformation processes that are not conventional forging in the strict sense, but are indispensable for the forging industry as a whole, such as shearing, trimming, piercing, bending, coining and hot padding.

## ***Economics in Die Design***

The cost of die materials is a relatively low percentage of the overall costs of sinking a die. Using a typical hammer as an example, the cost of the material for a new die is approximately 18% to 25% of the total cost. Which means that you as a die designer have much control of over 75% of the cost of producing a die.

## ***Effect of Shape on Forging Pressure and Die Filling***

Most impression die forgings are of complex shape. In such complex shapes, smooth, proper metal flow and die filling are necessary for forging a defect-free part with the required mechanical properties.

## ***Die Wear in Hot Forging***

Die life in a forging operation is dependent on the mechanical properties of the die steel at the surface conditions. Properties of die steel, which determine their selection as die material for hot forgings are the ability to harden uniformly, resist wear, resistance to plastic deformation, the ability to withstand shock and the ability to resist heat checking.

## ***Guidelines for Precision Hot Forging***

Economic pressures have forced even the most reluctant forgers to improve their present manufacturing techniques so they can be cost competitive and maintain higher quality than the rival processes. Reduced cost and increased quality of forgings benefit the forging industry, first by increasing profit margins and second, by helping to maintain markets or regain those lost in recent years.

## ***The Manufacture of Close Tolerance Forging Dies***

Forgings made in impression dies will be dimensionally accurate only if the finished cavity in each die half is the correct shape, and if the two cavities are exactly aligned when the dies are installed in the hammer or press. In this section, we will consider only the first point, making dimensionally correct cavities.

## ***Problem-Solving Session***

On the last day, the class will divide into small groups, and aided by an instructor, each group will review and tentatively solve an assigned die design problem.

---

***Students are encouraged to submit a real life problem from their company for the problem-solving session. A problem-solving report form will be sent to registrants in advance, providing an opportunity to submit a "problem" for consideration. A brief statement of the problem, material being forged, drawings of parts and/or dies, sample part, (if size permits), and a description of effort (what has been tried that did not work) will be needed.***

# Theory and Applications of Forging & Die Design

## FEE / HOTEL / REGISTRATION / CLASS SCHEDULE

### FEES/MATERIALS REQUIRED

Tuition is \$1,099.00 per student (FIA member), \$1699.00 (FIA non-member), which includes class materials, instructor fees, Monday night dinner, lunches and graduation. Continental breakfast is served each day to attendees. Participants will pay individually for dinner Tuesday and Wednesday nights, any evening activities in free time, and hotel charges. Students are also expected to furnish a small inexpensive calculator for use in class, and some minimum drawing utensils including a variable angle, a scale, and/or straight edge of at least 9-inch length.

FIA will honor FIA member registrations first. Member and non-member students will be notified of acceptance on May 28<sup>th</sup>. If FIA cannot accommodate non-member registration, the fee will be returned. Please call the FIA office at 216-781-6260 if you have questions.

### HOTEL

The Residence Inn – Marriott room rate is \$129.00 plus tax (currently 15.5%) per night, for single or double occupancy. Indicate your requirements on the enclosed registration form. Participants are expected to pay hotel room charge direct upon departure. Major credit cards and traveler's checks are accepted. There is a self-parking garage adjoining the hotel, and valet parking is \$18.00 per day. FIA will coordinate all reservations and overnight accommodations for participants at the Residence Inn – Marriott, Cleveland, Ohio.

### REGISTRATION/CANCELLATION PROCEDURE

All participants should register for the class by completing and returning the enclosed registration form to FIA for receipt by May 28, 2010 with tuition fee of \$1,099.00 for each FIA member registration entry (\$1699.00 for non-members). If necessary, phone registrations may be made to the FIA office; but payment must then be received prior to the program. FIA will accept and confirm registrations by FAX on or before May 28<sup>th</sup>, honoring member requests first. Please do not make air reservations until you are notified by FIA of acceptance in school.

**Cancellation after May 28<sup>th</sup> is subject to the full tuition fee, which will be applied to the operation of the course.** Substitutions within each company may be made, but FIA should be notified in each case.

### ARRIVAL/DEPARTURE TIMES

Participants should arrive in time for Monday, June 14<sup>th</sup> registration at 7:30 am. Formal instruction begins at 8:00 am Monday and continues through Thursday until 4:00 p.m. Please do not schedule return flights before 6:00 p.m. on Thursday, June 17<sup>th</sup>. From Cleveland Hopkins Airport attendees may either take a taxi, (fare is about \$27.00 one way), **or the Cleveland Rapid for \$1.50, each way.** You may access the Cleveland Rapid from the lower level of the Airport. The Rapid will take you to Tower City Station, where you will walk up to ground level to Prospect Ave. You may also phone Hopkins Airport Service at 1-800-543-9912 - (\$37.00 one way Hopkins to downtown Cleveland hotels), or CBS Transportation at 1-800-795-6402 (\$25.00 one way Hopkins/Radisson Hotel. Transportation costs are approximate and are subject to change by the transportation company.

### CLASS SCHEDULE

Registration and a continental breakfast start at 7:30 a.m. Monday, June 14<sup>th</sup>, with the School beginning each day at 8:00 a.m. On Monday evening a class dinner is scheduled for 5:30 p.m. School work covers 27 class hours of study, workshop and discussion. Classes end Thursday, June 17<sup>th</sup> by 4:00 p.m. Attendance for all sessions is mandatory, so flight departures should be scheduled no earlier than 6:00 p.m. on Thursday.

---

### **WHO SHOULD ATTEND**

The School is a blend of theory, mathematics and practical information on the subject of forging and forging die design. There are no specific background requirements for attendees. Although a basic knowledge of engineering is a plus, many students without such training receive substantial value from the analysis, problem-solving and discussion sessions. Individual managers are best suited to determine who would receive maximum value.

### **RETURN ON INVESTMENT**

FIA is committed to strong educational programs for forging industry personnel. A fundamental knowledge of metal flow principles, die design practice and forging technology is essential for employees who need to become strong contributors to cost reduction and profitability. Most attendees also rate informal discussions with other industry personnel as a strong bonus of FIA School attendance.

### **INSTRUCTORS**

Instructors are selected for their knowledge, experience and ability to communicate well in a classroom environment. The principal portion of the School will be presented by Dr. Joe Domblesky of Marquette University, Dr. Chester J. Van Tyne of Colorado School of Mines, John Walters of Scientific Forming Technologies, Charles J. Crout of Ajax Technologies, and Richard Douglas of JRD Associates.

### **STUDENT PROBLEM SOLVING SESSION**

Companies are encouraged to submit a real life problem for the problem-solving session. A problem-solving submission form will be sent to registrants in advance, providing an opportunity to submit a "problem" for consideration. A brief statement of the problem, material being forged, drawings of parts and/or dies, sample part, (if size permits), and a description of effort (what has been tried that didn't work) will be needed. This information should be submitted to FIA, attention George Layne, two weeks prior to class.

---

### **COMMENTS FROM PRIOR ATTENDEES**

- *"All instructors are skilled, excellent speakers, very well prepared for their presentation"*
- *"Excellent course – connected theory with practice very well"*
- *"Best part of the class was getting together/meeting with other people from the industry"*
- *"I gained a new understanding of the forging process"*
- *"Excellent course, especially for someone new to the forging industry"*
- *"This is a great movement to keep manufacturing strong in the U.S."*
- *"I will be able to use a lot of information learned at this course in our plant to improve some operations"*
- *"Thanks for the great info, atmosphere, and hospitality. Truly great!"*

# Theory and Applications of Forging & Die Design

June 14 – 17, 2010

Marriott Residence Inn, Cleveland, OH

## Registration Form

Please register the following individual(s) from our company. Payment of \$1,099.00 (FIA member), \$1699.00 (FIA non-member) tuition fee for each registrant should accompany this form. Fees are non-refundable after May 28, 2010 (substitutions allowed). Participants will be expected to pay hotel charges direct upon departure.

### REGISTRATION:

Name \_\_\_\_\_ Title \_\_\_\_\_ Nickname \_\_\_\_\_

Name \_\_\_\_\_ Title \_\_\_\_\_ Nickname \_\_\_\_\_

Company \_\_\_\_\_

Address \_\_\_\_\_

City/State/Zip \_\_\_\_\_

Phone \_\_\_\_\_

Fax \_\_\_\_\_

E-mail \_\_\_\_\_

**\* Please do not make travel arrangements until notified of your acceptance in the School.**

**ACCOMMODATIONS:** Residence Inn Hotel room rate - \$129.00 + tax. (Attendees pay direct to hotel upon departure):

I/we will need ( ) 1 room ( ) 2 rooms for: arrival \_\_\_\_\_\*\* departure \_\_\_\_\_  
(date) (date)

### PAYMENT TO FIA:

\$1,099.00 (FIA member) \$1699.00 (FIA non-member) TOTAL TUITION FEE \_\_\_\_\_

**Method of Payment:**  Check enclosed (Payable to FIA)  Credit Card (complete next line)

VISA  MC  American Express Exp. Date \_\_\_\_\_ Card Number \_\_\_\_\_  
Security Code (3-digit # on back of card) \_\_\_\_\_

**( ) Yes, I plan on submitting a student problem including drawing of parts or dies and the parts themselves (if size permits) for study by the attendees. FIA will forward "Problem Description" Form with confirmation.**

\*\* MUST ARRIVE BY 7:30 A.M. MONDAY, JUNE 14<sup>th</sup> TO ATTEND ALL CLASSES FOR GRADUATION. PLEASE DO NOT SCHEDULE RETURN FLIGHTS BEFORE 6:00 P.M. ON JUNE 17<sup>th</sup>.

**Please Return by May 28, 2010 to: Connie Long**

Forging Industry Association, 25 West Prospect Avenue, #300, Cleveland, OH 44115

Phone: 216-781-6260

FAX: 216-781-0102

E-mail: info@forging.org